

Product introduction

Description



PS131-TSR-S

Monosilicon electronic pressure switch

The new generation of PS131 sensors was developed in close coordination with the users. Its modern and userfriendly design stands out. High overload protection and best accuracy.

PS131 is a pressure sensor with a pressure switch to safely and absolutely measure and monitor gauge pressures. It is highly stable and has a function check and onsite information due to its OLED and digital display. It can be rotated up to 350° if placed on the upper part of the house, also the display contents can be rotated up and down.

Main parameters

Pressure types	Gauge pressure
Measuring range	2kPa-40MPa, please refer to the ordering information chapter
Output signal	4-20mA, 1-5VDC, Modbus-RTU/RS485, PNP or NPN output, customer
Reference accuracy	±0.1%URL

Field of application

Pressure, level measurement

Approvals



Measuring medium

The fluids which compatible with wetted parts

Technical Specifications

Measuring range and limit

Nominal value	Smallest calibratable span	Lower range limit (LRL)	Upper range limit (URL)	Overload limit
40kPa	2kPa	-40kPa	40kPa	1MPa
250kPa	12.5kPa	-100kPa	250kPa	4MPa
1MPa	50kPa	-100kPa	1MPa	6MPa
3MPa	150kPa	-0.1MPa	3MPa	15MPa
10MPa	500kPa	-0.1MPa	10MPa	20MPa
40MPa	5MPa	-0.1MPa	40MPa	80MPa

Above measurement range can be replaced by kg/cm², MPa and kPa units. Provide other measuring range according to requirements. Adjust requirements: lower range value (LRV) and upper range value (URV) can be adjusted within the scope of the upper and lower range limit, smallest calibratable span ≤ | URV-LRV | ≤ upper range limit

Standard specifications and reference conditions

Test standard: GB/T28474 / IEC60770; Zero based-calibration span, Linear output, Silicon oil filling, 316L stainless steel isolated diaphragm.

Performance specifications

The overall performance including but not limited to 【reference accuracy】, 【environment temperature effects】 and other comprehensive error

Typical accuracy: ±0.1%URL

Stability: ±0.2% URL/ 5 years

Reference accuracy

Including linearity, hysteresis and repeatability. calibration temperature: 20°C ± 5°C

Linear output accuracy	TD ≤10(Note 1)	±0.1%URL	Nominal value: 40kPa, 250kPa 1MPa, 3MPa 10MPa, 40MPa
	10<TD≤20	±0.01TD% URL	

Note 1: TD is Turn down, TD=URL/ | URV-LRV |

Power supply effects

Zero and span change should not be more than ± 0.005% URL/V

Mounting position effects

Apply to any position. Install error less than 400Pa, which can be corrected by PV=0 reset.

Vibration effects

According to GB/T 1827.3/IEC61298-3 tests, <0.1% URL

Output signal

Signal	Type	Output
4-20mA	Linearity	Three wire
PNP or NPN	Non-Linearity	Three wire
1-5VDC	Linearity	Three wire
Modbus-RTU/RS485	Linearity	Four wire

Ambient temperature effects(Typical)

Within the range -20-80°C total impact ±(0.1+0.15TD)%URL

Insulation resistance

≥20M Ω@, 100VDC

Technical Specifications

Damping time

Startup after power off : ≤3S
Normal services after data recovery: ≤10S

Weight

Net weight: about 1 kg (without mounting bracket and process connection adaptor)
--

Environment condition

Items	Operational condition
Working temperature	-40-85°C
Storage temperature	-40-85°C
Media temperature	Silicon oil filling: -40-120°C
Working humidity	0-95%RH@40°C
Protection class	IP67

Technical Specifications

Signal output	4-20mA	1-5VDC	RS485
Power supply voltage	12-30VDC	12-30VDC	12-30VDC
Electric current	≤60mA	≤60mA	≤45mA
Load resistance(Ω)	<(U-12)/0.06	≥5k, recommend 100k	/
Transmission distance	<1000m	<5m	<1200m
Power consumption	≤1.44W(4-20mA+ transistor+ OLED display @24VDC)	≤ 1.44mW (1-5VDC + transistor + OLED display @24VDC)	≤1.08W(RS485+ transistor + OLED display @24VDC)

*For this output type, the load resistance value in communication is 250Ω

** The load resistance value 0-2119Ω is in nominal working condition, 250-600Ω is HART communication

EMC environment(only for current signal output)

NO.	Test items	Basic standards	Test conditions	Performance level
1	Radiated interference	GB/T 9254/CISPR22	30MHz-1000MHz	OK
2	Conducted interference (DC power port)	GB/T 9254/CISPR22	0.15MHz-30MHz	OK
3	Electrostatic discharge immunity test (ESD)	GB/T 17626.2/IEC61000-4-2	4kV(Contact),8kV(Air)	B(Note2)
4	Immunity to radio frequency EM-fields	GB/T 17626.3/IEC61000-4-3	10V/m(80MHz-1GHz)	A(Note1)
5	Power frequency magnetic field Immunity test	GB/T 17626.8/IEC61000-4-8	30A/m	A(Note1)
6	Electrical fast transient / Burst Immunity Test	GB/T 17626.4/IEC61000-4-4	2kV(5/50ns,100kHz)	B(Note2)
7	Surge immunity requirements	GB/T 17626.5/IEC61000-4-5	1kV(Line to line) 2kV(Line to ground) (1.2us/50us)	B(Note2)
8	Immunity to conducted disturbances induced by radio frequency fields	GB/T 17626.6/IEC61000-4-6	3V(150kHz-80MHz)	A(Note1)

(Note 1)Performance level A: The performance within the limits of normal technical specifications.

(Note 2)Performance level B: Temporary reduction or loss of functionality or performance, it can restore itself. The actual operating conditions, storage and data will not be changed.

Menu function

Transmission module type

Output signal	Local control	Remote control
4-20mA	OLED/3 buttons on body	-

LED display unit

Display mode	Details
Pressure & Unit	Two-row display: pressure value and unit
XX.X&P&Unit	Three-row display: percentage, pressure value and unit
SPn&P&RPn	Three-row display: SPn, pressure value and RPn

Unit

Unit	Definition
kPa	Kilopascal
MPa	Megapascals
bar	Bar
psi	Pounds per square inch
mmHg	Millimetre(s) of mercury@0°C
mmH2O	Millimeter of water@4°C
mH2O	Meter of water@4°C
inH2O	Inches of water@4°C
ftH2O	Feet of water@4°C
inHg	Inches of mercury@0°C
mHg	Meter mercury column@0°C
TORR	Torr
mbar	Millibar
g/cm2	Gram per square centimeter
kg/cm2	Kilogram per square centimeter
Pa	PA
ATM	Standard atmospheric pressure
mm	Millimeter(Note 1)
m	Meter(Note 1)

Note 1: length unit need mark medium density

Measuring menu set

Mark	State
URV	Upper range value, 20mA
LRV	Lower range value, 4mA

Analog output type

Parameters	Output type
mA LINER	Linearity

Alarm signal

Parameter	Description
AOLC	When too small pressure lead to output current < AOLC setting value, display Out<AOLC
AOHC	When too large pressure lead to output current > AOHC setting value, display Out>AOHC

Fix output

Parameter	Fix output value
FIX/C NO	None
3.8000	3.8000mA
4.0000	4.0000mA
8.0000	8.0000mA
12.0000	12.0000mA
16.0000	16.0000mA
20.0000	20.0000mA
20.8000	20.8000mA

Quick menu

Parameter	Instruction
PV=0	Set current analog output to zero value.(gauge pressure, differential pressure)
Zero adjustment	4mA re-range with pressure
Span adjustment	20mA re-range with pressure
Restore factory setting	Restore backup data when error

Disclaimer: all the data used in the product description is not legally binding. Relevant technical details may be changed due to further improve

Product selection instruction

Sensor type select instruction

Code	Nominal value	Description
S403G	40kPa	Range -40kPa-40kPa, smallest calibratable span 2kPa
S254G	250kPa	Range -100kPa-250kPa, smallest calibratable span 12.5kPa
S105G	1MPa	Range -0.1MPa-1MPa, smallest calibratable span 50kPa
S305G	3MPa	Range -0.1MPa-3MPa, smallest calibratable span 150kPa
S106G	10MPa	Range -0.1MPa-10MPa, smallest calibratable span 500kPa
S406S	40MPa	Range -0.1MPa-40MPa, smallest calibratable span 5MPa

Adjust requirements: lower range value (LRV) and upper range value (URV) can be adjusted within the scope of the upper and lower range limit, smallest calibratable span $\leq |URV - LRV| \leq URL$

Code	Position	Instruction
S	Isolated diaphragm material	SUS316L
H		Hastelloy C
S	Isolated filling fluid	Silicon oil, process temperature: -45~205°C
D		Fluorocarbon oil, process temperature: -45-160°C
F	Sensor seal	Stainless steel welding seal

Isolated diaphragm (S/H)



Electrical connection select instruction

Code	Description
H3	Aviation plug, M12*1, 5 pins, IP67
H4	Aviation plug, M12*1, 4 pins, IP67

Aviation plug (H3), M12*1 (5 pins)



Aviation plug (H4), M12*1 (4 pins)



Aviation plug (H3), M12*1 (5 pins)

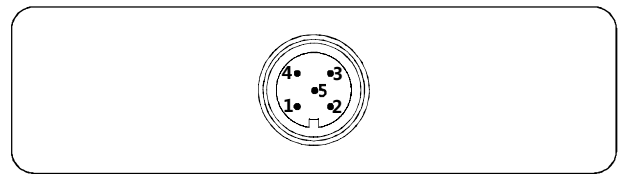

1	2	3	4	5
Power+	RS485A+	Power-	RS485B-	*Signal-
Power+	Transistor output 2	Power-	Transistor output 1	*Signal-

*Signal type: 4-20mA, 1-5VDC

Aviation plug (H4), M12*1 (4 pins)

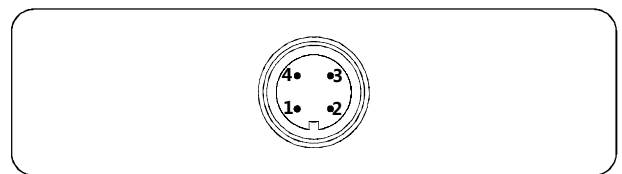

1	2	3	4
Power+	RS485A+	Power-	RS485B-
Power+	Transistor output 2	Power-	Transistor output 1
Power+	Transistor output 2	Power-	Transistor output 1
Power+		Power-	
Power+	*Signal	Power-	Transistor output 1

*Signal type: 4-20mA, 1-5VDC

Product selection instruction

Electrical connection accessories

Aviation plug straighter(J1)

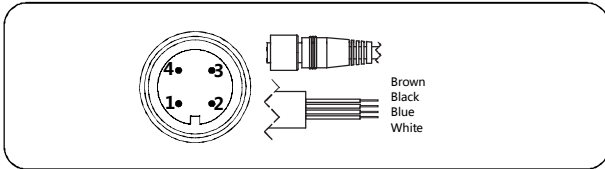

1/Brown	2/White	3/Blue	4/Black
Power+	RS485A+	Power-	RS485B-
Power+	Transistor output 2	Power-	Transistor output 1
Power+	Transistor output 2	Power-	
Power+		Power-	Transistor output 1
Power+	*Signal+	Power-	Transistor output 1

*Signal type: 4-20mA, 1-5VDC

Aviation plug elbow(J2)

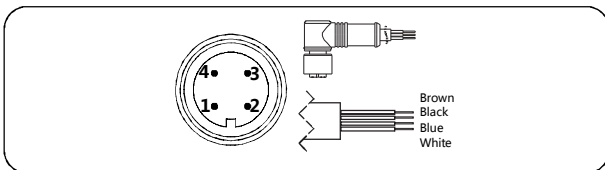

1/Brown	2/White	3/Blue	4/Black
Power+	RS485A+	Power-	RS485B-
Power+	Transistor output 2	Power-	Transistor output 1
Power+	Transistor output 2	Power-	
Power+		Power-	Transistor output 1
Power+	*Signal+	Power-	Transistor output 1

*Signal type: 4-20mA, 1-5VDC

Aviation plug straighter(J3)

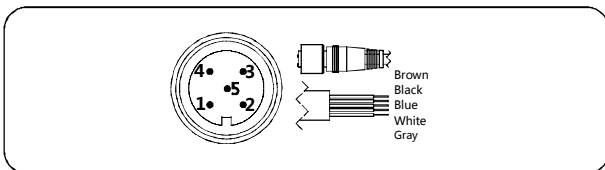

1/Brown	2/White	3/Blue	4/Black	5/Gray
Power+	RS485A+	Power-	RS485B-	*Signal+
Power+	Transistor output 2	Power-	Transistor output 1	*Signal+

*Signal type: 4-20mA, 1-5VDC

Aviation plug straighter(J4)

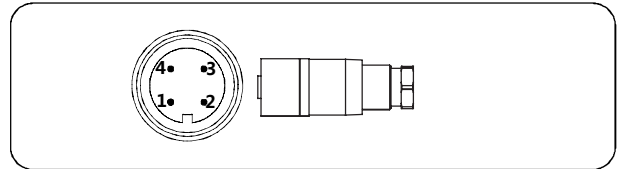

1	2	3	4
Power+	RS485A+	Power-	RS485B-
Power+	Transistor output 2	Power-	Transistor output 1
Power+	Transistor output 2	Power-	
Power+		Power-	Transistor output 1
Power+	*Signal+	Power-	Transistor output 1

*Signal type: 4-20mA, 1-5VDC

Aviation plug elbow(J5)

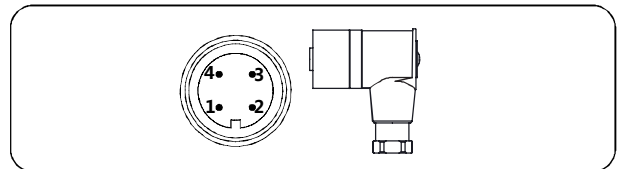

1	2	3	4
Power+	RS485A+	Power-	RS485B-
Power+	Transistor output 2	Power-	Transistor output 1
Power+	Transistor output 2	Power-	
Power+		Power-	Transistor output 1
Power+	*Signal+	Power-	Transistor output 1

*Signal type: 4-20mA, 1-5VDC

Aviation plug straighter(J6)

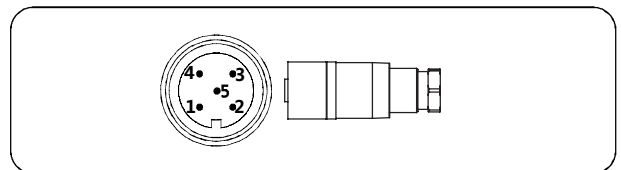

1	2	3	4	5
Power+	RS485A+	Power-	RS485B-	*Signal+
Power+	Transistor output 2	Power-	Transistor output 1	*Signal+

*Signal type: 4-20mA, 1-5VDC

Product selection instruction

Electrical connection accessories

Aviation plug elbow(J7)

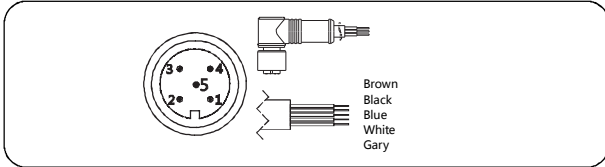

1	2	3	4	5
Power+	RS485A+	Power-	RS485B-	*Signal+
Power+	Transistor output 2	Power-	Transistor output 1	*Signal+

*Signal type: 4-20mA, 1-5VDC

Aviation plug elbow(J8)

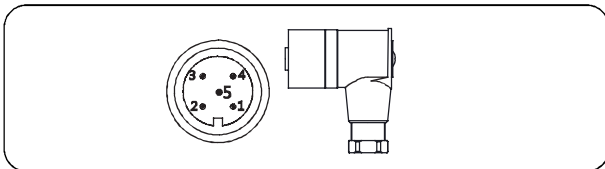

1	2	3	4	5
Power+	RS485A+	Power-	RS485B-	*Signal+
Power+	Transistor output 2	Power-	Transistor output 1	*Signal+

*Signal type: 4-20mA, 1-5VDC

Output signal select instruction

Code	Description
FN	4-20mA+NPN, power supply: 12-30VDC
FP	4-20mA+PNP, power supply: 12-30VDC

Display module (E)

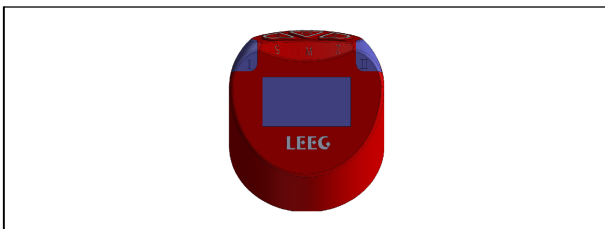

Contact alarm select instruction

Code	Type	Description
1	Output contact	One PNP or NPN output
2		Two PNP or NPN output

C1	First contact alarm value	Customer setting
A1		Factory setting
L1	First alarm method	Lower than alarm value, output high electrical level
H1		Higher than alarm value, output high electrical level
W1		Alarming in window
W2		Alarming out window
C2	Second contact alarm value	Customer setting
A2		Factory setting
L2	Second alarm method	Lower than alarm value, output high electrical level
H2		Higher than alarm value, output high electrical level
W1		Alarming in window
W2		Alarming out window

Process connection select instruction

Code	Type	Description
4	Material	SUS304
6		SUS316
M01	Specifications	M20*1.5(M), Φ3 pressure lead hole, GB/T193-2003, ISO261
G01		G1/2(M), Φ3 pressure lead hole, EN837
G02		G1/4(M), Φ3 pressure lead hole, EN837
G08		G1/4(M), Φ3 pressure lead hole, GB/T7037, ISO228, DIN16288, Bs2779, seal reference DIN3852-E(back-end seal)
R01		1/2-14NPT(M), Φ3 pressure lead hole, GB/T12716, ANSI/ASME B1.20.1B1.20.1
R02		1/4-18NPT(M), Φ3 pressure lead hole, GB/T12716, ANSI/ASME B1.20.1B1.20.1
R03		1/2-14NPT(F), Φ3 pressure lead hole, GB/T12716, ANSI/ASME B1.20.1B1.20.1
R04		1/4-18NPT(F), Φ3 pressure lead hole, GB/T12716, ANSI/ASME B1.20.1B1.20.1

Product drawing and dimension

PS131-TSR-S drawing and dimension (unit: mm)

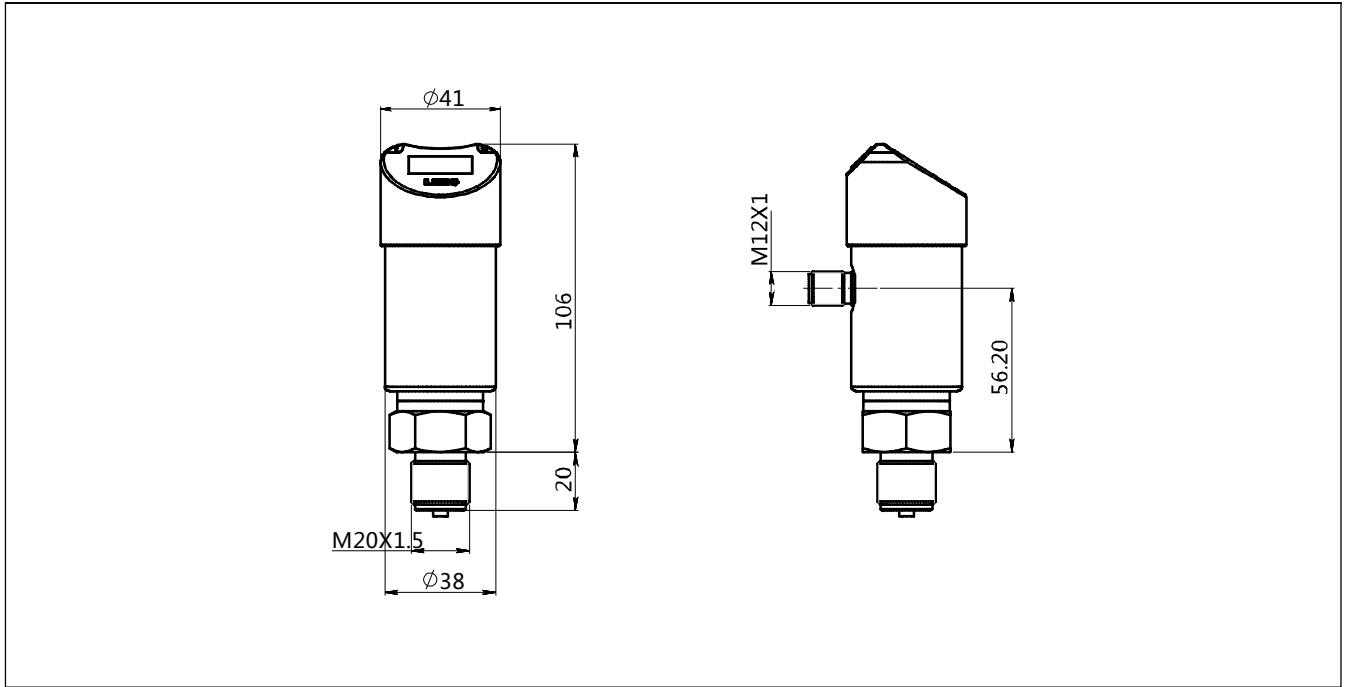

Process connection(M01) (unit: mm)

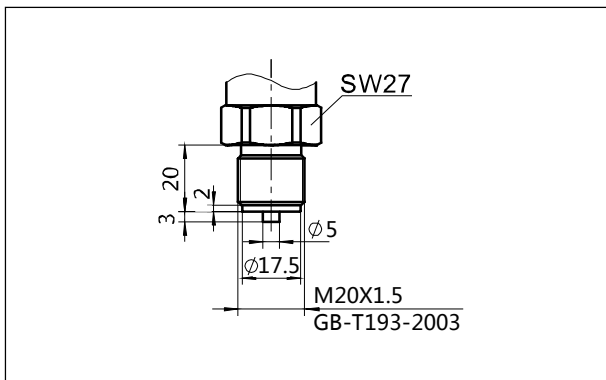

Process connection(G01) (unit: mm)

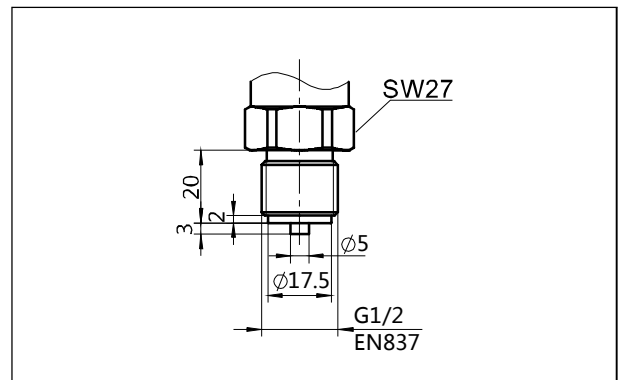

Product drawing and dimension

Process connection(G02) (unit: mm)

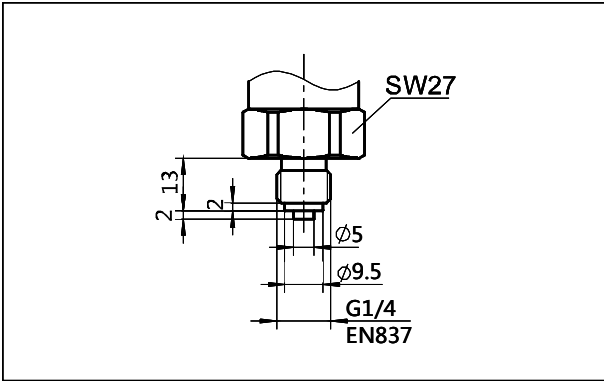

Process connection(G08) (unit: mm)

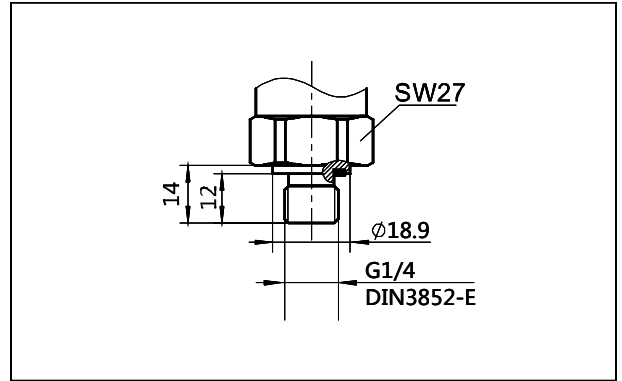

Process connection (R01) (unit: mm)

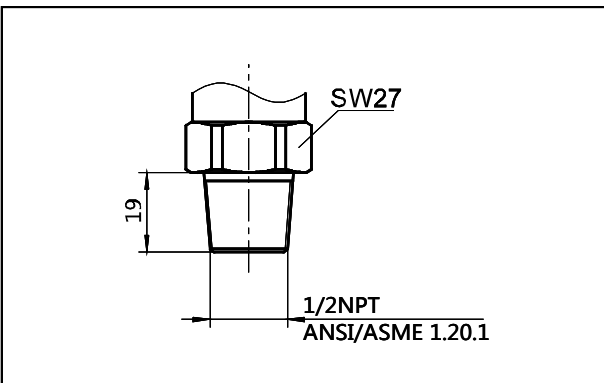

Process connection (R02) (unit: mm)

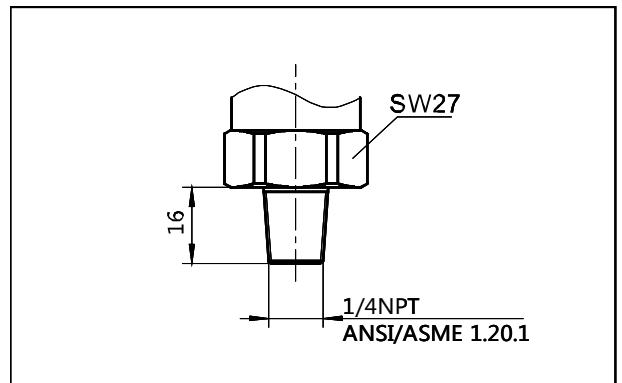

Process connection (R03) (unit: mm)

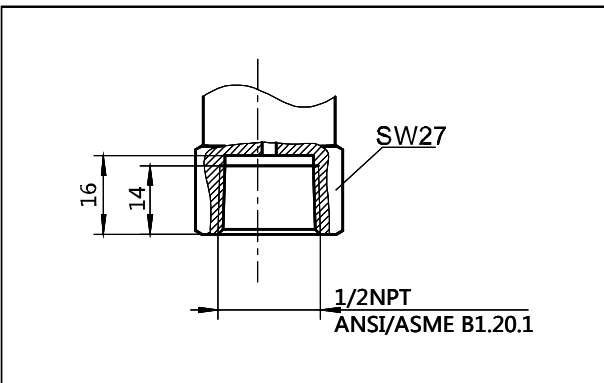

Process connection (R04) (unit: mm)

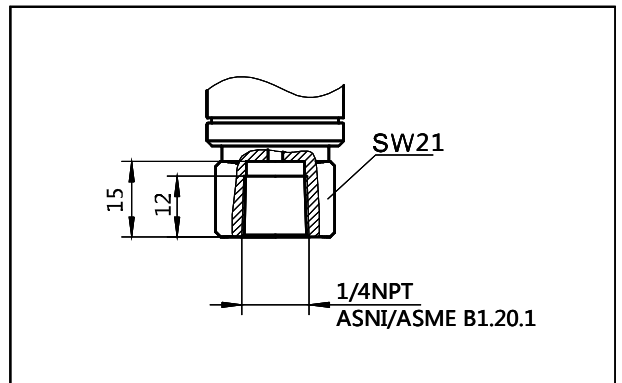

Product drawing and dimension

Heat exchange connector (N1) (unit: mm)

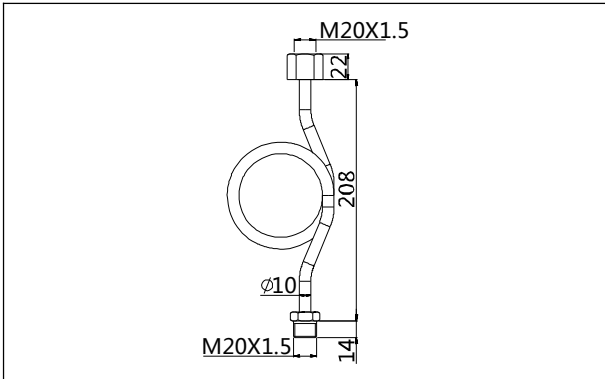

Heat exchange connector (N2) (unit: mm)

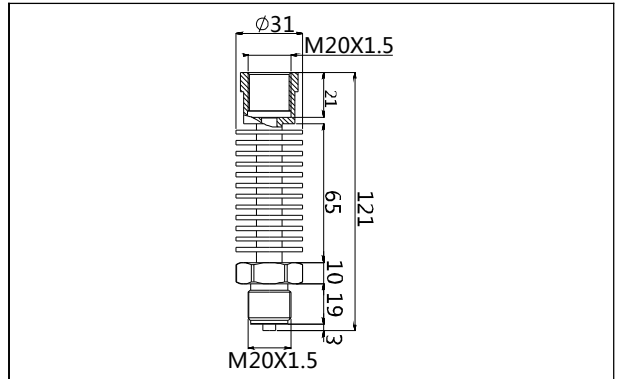

Welding adaptor (Z1) (unit: mm)

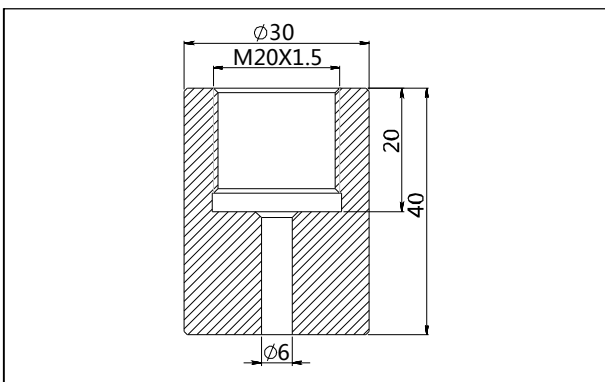

Welding adaptor (Z2) (unit: mm)

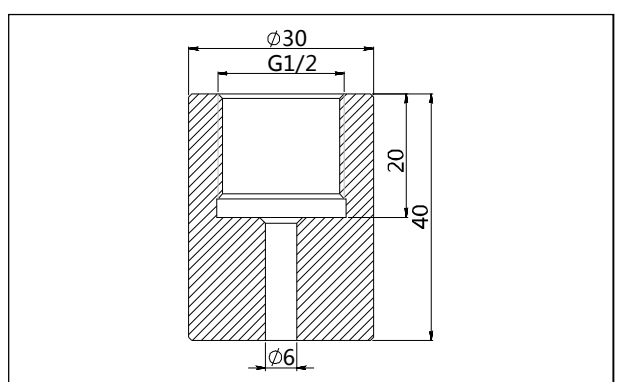

Aviation female plug straighter (4 pins) (J1) (unit: mm)

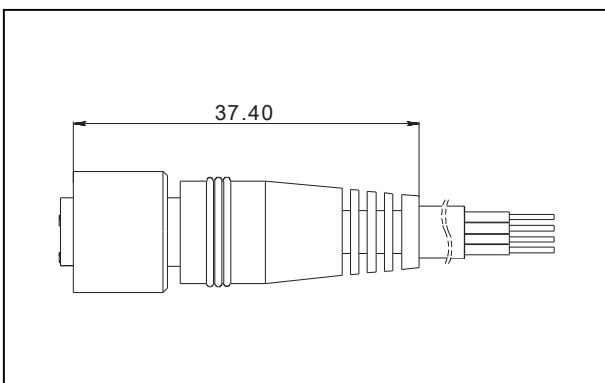

Aviation female plug elbow (4 pins) (J2) (unit: mm)

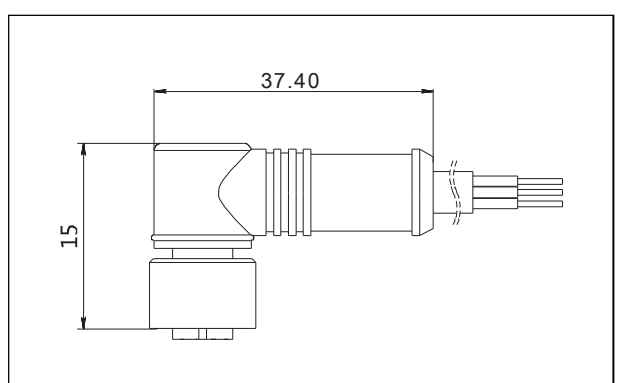

Product drawing and dimension

Aviation female plug straighter (5 pins) (J3) (unit: mm)

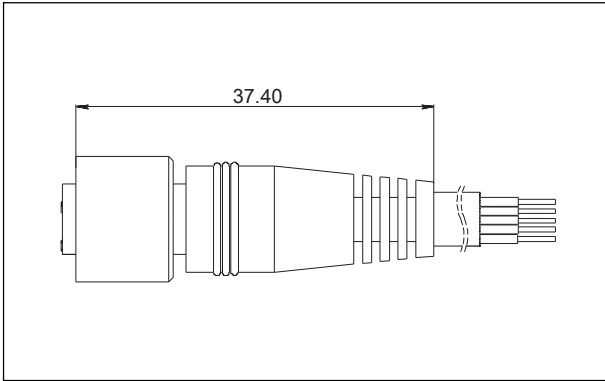

Aviation female plug straighter (4 pins) (J4) (unit: mm)

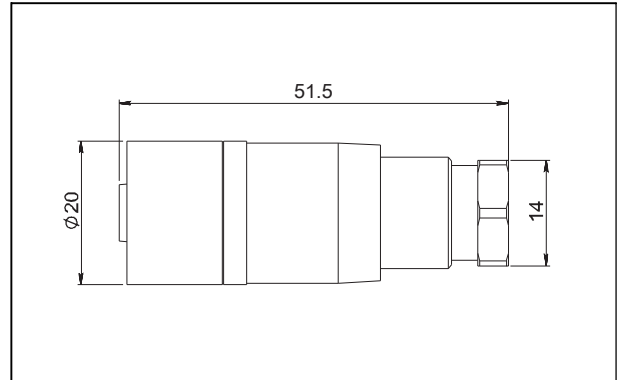

Aviation female plug elbow (4 pins) (J5) (unit: mm)

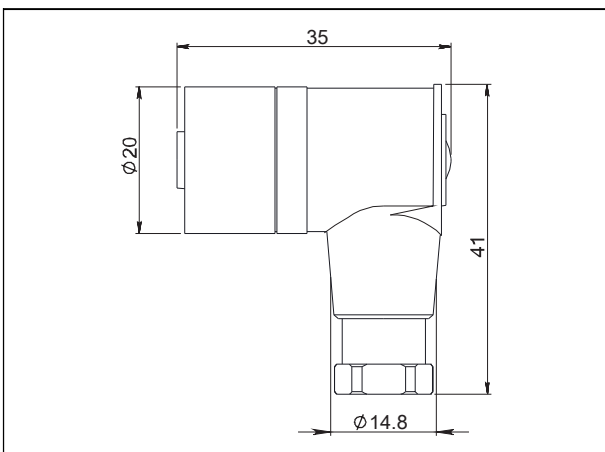

Aviation female plug straighter (5 pins) (J6) (unit: mm)

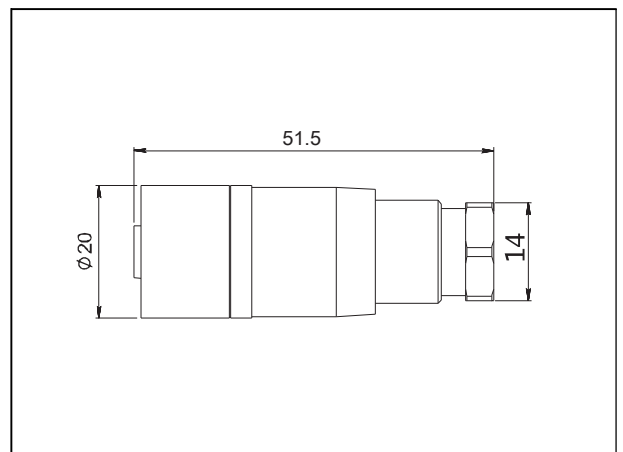

Aviation female plug elbow (5 pins) (J7) (unit: mm)

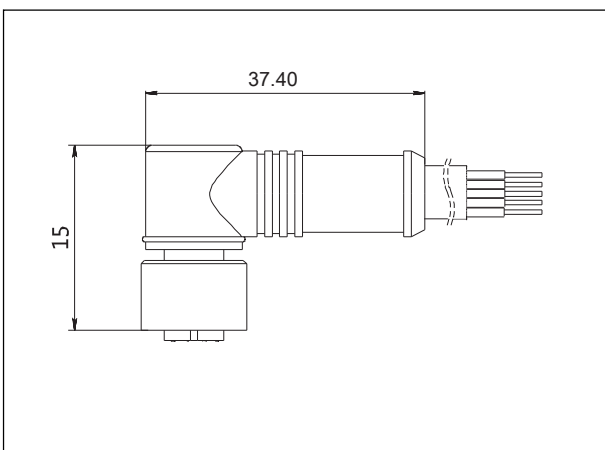

Aviation female plug elbow (5 pins) (J8) (unit: mm)

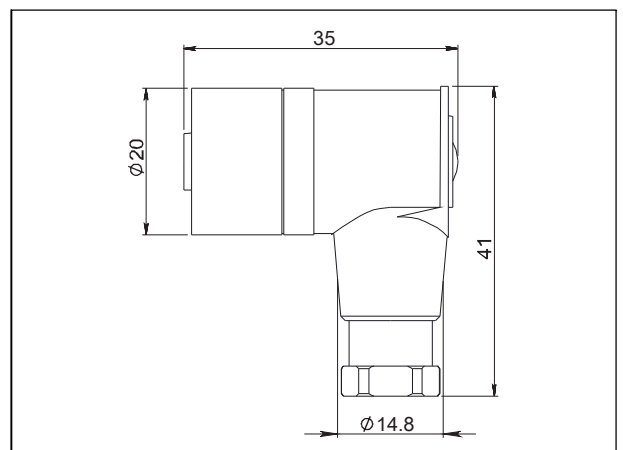

Disclaimer: all the data used in the product description is not legally binding. Relevant technical details may be changed due to further improve

Ordering information chapter

Item	Parameters	Code	Instruction	(*)Fast delivery available	
	Model	PS131-TSR	Monosilicon electronic pressure switch		
Sensor	Separator	-	Detailed specifications as following		
	Pressure range code	S403G	Nominal value(URL): 40kPa		
		S254G	Nominal value(URL): 250kPa	*	
		S105G	Nominal value(URL): 1MPa	*	
		S305G	Nominal value(URL): 3MPa	*	
		S106G	Nominal value(URL): 10MPa	*	
		S406S	Nominal value(URL): 40MPa		
	Isolated diaphragm material	S	SUS316		*
		H	Hastelloy C		
	Isolated filling fluid	S	Silicon oil, process temperature: -45-250°C		*
		D	Fluorocarbon oil, process temperature: -45-160°C		
Sensor seal	F	Stainless steel welding seal		*	
Electrical connection	Separator	-	Detailed specifications as following		
	Electrical connection	H3	Aviation plug, M12*1(5 pins), IP67 (For signal 4-20mA+2 way transistor output)	*	
		H4	Aviation plug, M12*1(4 pins), IP67	*	
	Cable entry protector	R0	None	*	
Output	Separator	-	Detailed specifications as following		
	Output signal	FN	4-20mA + NPN, power supply: 12-30VDC		
		FP	4-20mA + PNP, power supply: 12-30VDC	*	
	Display mode	E	With OLED display	*	
		A	Without display		
	Output contact	1	One way output contact		
		2	Two way output contact		
	First contact alarm value	C1	Customer setting		
		A1	Factory setting		
	First alarm method	L1	N, P: Lower than alarm value, output high level		
		H1	N, P: Higher than alarm value, output high level		
		W1	Alarming in window		
		W2	Alarming out window		
	Second contact alarm value	C2	Customer setting		
		A2	Factory setting		
	Second alarm method	L2	N, P: Lower than alarm value, output high electrical level		
		H2	N, P: Higher than alarm value, output high electrical level		
		W1	Alarming in window		
		W2	Alarming out window		

Disclaimer: all the data used in the product description is not legally binding. Relevant technical details may be changed due to further improve

Ordering information chapter

Tube type	Separator	-	Detailed specifications as following		
	Tube	57	Stainless steel tube length: 57mm		
Process connection	Separator	-	Detailed specifications as following		
	Material	4	SUS304		
		6	SUS316	*	
	Specification	M01	M20*1.5 (M), Φ3 pressure lead hole, GB/T193-2003, ISO261		*
		G01	G1/2 (M), Φ3 pressure lead hole, EN837		*
		G02	G1/4(M), Φ3 pressure lead hole, EN837		
		G08	G1/4(M), Φ3 pressure lead hole, GB/T7307, ISO228, DIN16288, BS2779, seal refers to DIN3852-E (back-end seal)		
		R01	1/2 -14NPT(M), Φ3 pressure lead hole, GB/T12716, ANSI/ASME B1.20.1		*
		R02	1/4 -18NPT(M), Φ3 pressure lead hole, GB/T12716, ANSI/ASME B1.20.1		
		R03	1/2 -14NPT(F), Φ3 pressure lead hole, GB/T12716, ANSI/ASME B1.20.1		
		R04	1/4 -18NPT(F), Φ3 pressure lead hole, GB/T12716, ANSI/ASME B1.20.1		
Additional options	Separator	-	Detailed specifications as following(multiple)		
	Factory setting pressure alarm value	*/A1-XXX	The first contact alarming value: XXX, the first two are valid numbers and the third is X-th power of ten. Unit: Pa		
		*/A2-XXX	The second contact alarming value: XXX, the first two are valid numbers and the third is X-th power of ten. Unit: Pa		
	Electrical connection accessory	/J1	Aviation female plug (straighter) with 2m cable, 4 pins, M12*1, IP67		
		/J2	Aviation female plug (elbow) with 2m cable, 4 pins, M12*1, IP67		
		/J3	Aviation female plug (straighter) with 2m cable, 5 pins, M12*1, IP67		
		/J4	Aviation female plug (straighter) without cable, 4 pins, M12*1, IP67		*
		/J5	Aviation female plug (elbow) without cable, 4 pins, M12*1, IP67		
		/J6	Aviation female plug (straighter) without cable, 5 pins, M12*1, IP67		*
		/J7	Aviation female plug (elbow) with 2m cable, 5 pins, M12*1, IP67		
		/J8	Aviation female plug (elbow) without cable, 5 pins, M12*1, IP67		*
	Process connection mounting accessory	/N1	Heat exchange connector, M20*1.5 (F) change to M20*1.5(M), SUS304 (Condenser pipe)		
		/N2	Heat exchange connector, M20*1.5 (F) change to M20*1.5(M), SUS304 (Cooling fin)		
	Process connection accessory	/Z1	Welding connector, M20*1.5(F), SUS304		
		/Z2	Welding adaptor, G1/2(F), SUS304		
	Display mode	/D1	According to your requirement		
	Calibration report	/Q1	Calibration report provided by our company		*
Approvals	/F3	CE certificate			

Disclaimer: all the data used in the product description is not legally binding. Relevant technical details may be changed due to further improve

Ordering information chapter

	Wetted parts treatment	/G1	Ungrease treatment	
		/G2	Electropolishing treatment	

*Eg, A1-105 means the pressure alarming value of A1 contact is $10 \times 10^5 = 10^6 = 1\text{MPa}$

Factory settings and parameters

Item	Menu mark	Factory setting value
Tag position	None	None
Analog output type	None	4-20mA
Display mode	DisMod	Pressure&Unit
Alarm URV	AOLC	3.800mA
Alarm LRV	AOHC	23.000mA

Item	Menu mark	Factory setting value
4mA Lower range value	LRV	According to the order value
20mA Upper range value	URV	According to the order value
Process unit	Unit	According to the order

Approvals

Factory certificate

Certification organization	Intertek
Quality management system	ISO9001-2008
Scope of certification	Design and production of pressure transmitter
Registration number	110804039

CE

Certificate organization	ISET
License scope	PS series electronic pressure switch
Mark	CE
EMC instruction	2014/30/EU
Standard	EN61326-1:2013
Registration number	IT011353LG161207



scan & follow LEEG wechat



check website for more info



Shanghai LEEG Instruments Co.,Ltd

ADD: No.100 Duhui Road, Minhang District, Shanghai China
Postcode:201109

Tel: (86) 21-31261976

Fax: (86) 21-31261975

E-mail:sales@leegsensor.com info@leegsensor.com

Web: www.leegsensor.com