

: &\$&\$\$\$\$

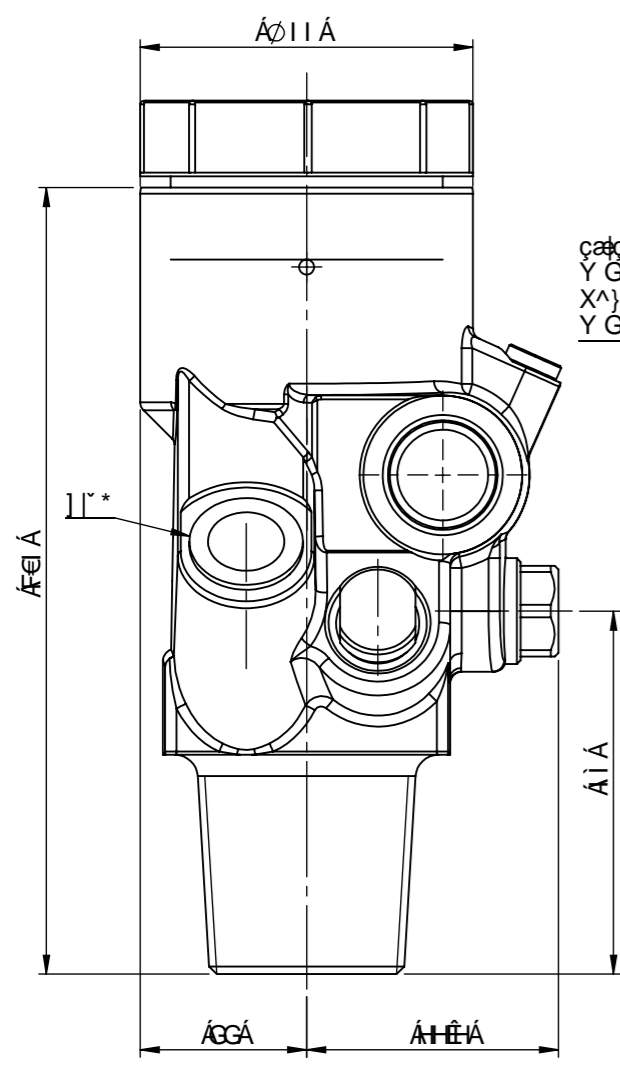

çac^Á d^c
Y GFÉ çFBI Á
X^ çæ * ç*
Y GFÉ çFBI Á

l^* @^æçac^
U&@ a^ æ ç^ ç^

l æ çæ } ^ & çæ }
ç@^ææ / ÖFB Ä
Ø | ^ ç^ ç^
æ * & ç * * / ÖFB Ä

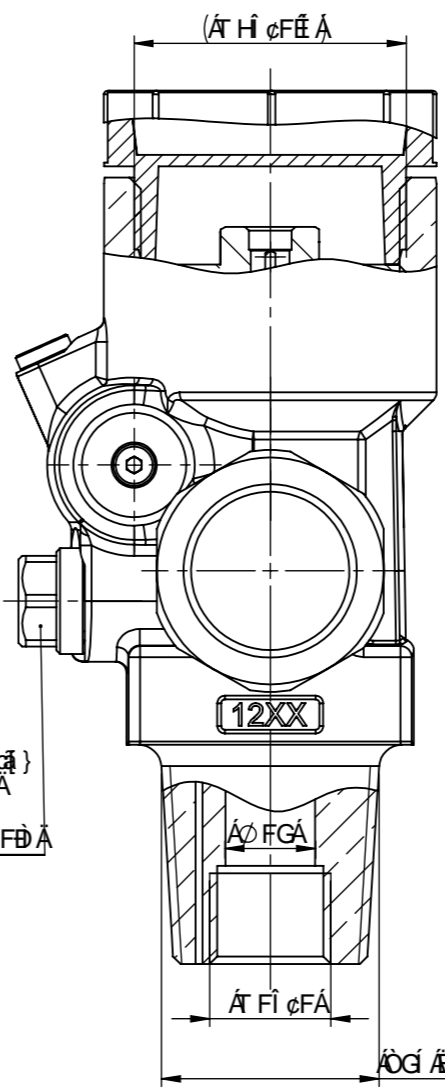

•æ^ç Á & ^
æ çæ * çæ *
ää & ÄPí çææ
U&@! @ æ * & çæ à ^
{ æ Ö! ç & @ æ ^
ÜPí çææ

ÖÖGí ÁÖÖÖ ÖÖP ÖÖU ÁFHI HÉÁ

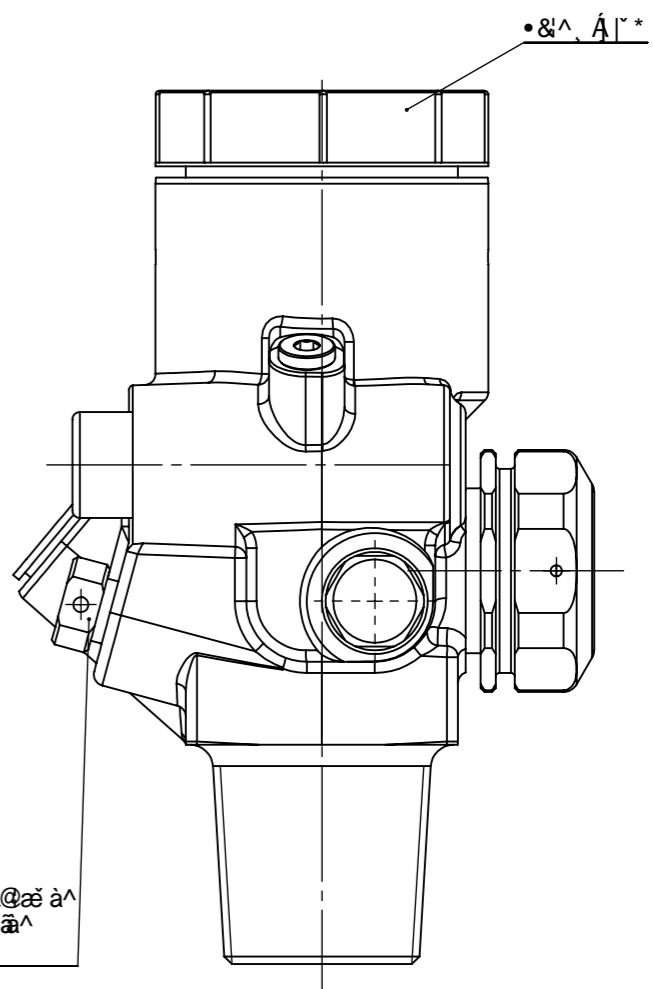

{ æ \ ä * K
æ } | çæ K
æ çæ \ Ä { à \ K
ääæ \ Ä æ ~ æ ç \ Ä K
ç@^ææ K
{ æ ~ æ ç \ Ä | • Ä | * [K
ç çæ \ ä & çæ * ^
, | \ ä * Ä | ^ ç * ^ æ ç \ ä * ^ ç \ Ä K VUÄH çææ

Äé | JÄÖVÜ ÖÖ çFÄV'] ÖÖÄ
ÖÖGÖÖÖÖÖ
RRRRÄÄ Y
G ÖÄÄÄ GFÉ çFBI Ä
Öæ { ^
VÖ

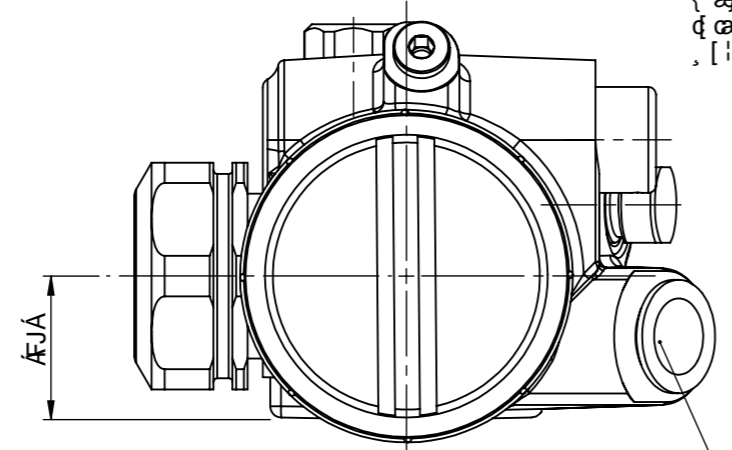

l | ^ çæ * ^
& } } ^ & çæ } Á FçF
T æ | { ^ ç | É
çæ * & ç * * Á FçF

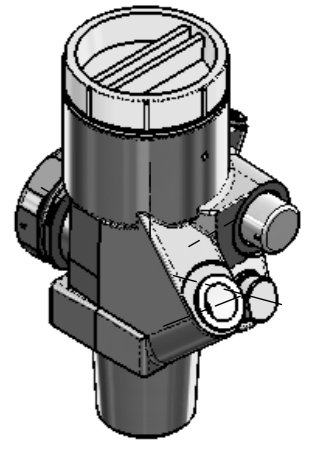

5" [Ya Y]brc YfUbnYb bUW 8-B -GC &+ , 1%a	Hc YfUbnYb ZÖF : cfa 'i bX@U[Y bUW 8-B -GC &+ , 1&<	5" Y'i bVYa Uç Yb ? UbyYb i bX FUXYb. F S&Z	: Yk Mh WU" %&\$, [I B 9GG CH< 9F K -G9 GD97 ÷ 9B. 8-A 9BG< BG 5F 9 -B A @A 9H9F G	
A UH YU :					
à FHEÉ Qá^çæ] æ *) *		T Š	FçFÉH	HV : çac^ Á Áæ^ á Á • çæ çæ } ÖP FG G í äæ Á [ç ^ & FG HÄÖT GççÄ çæ \ ä & çæ * ^ D	
æ FGÍ G Qá^çæ] æ *) *		Ø	G ÉFÉG		
çXYI YbXYfi b]	6YgWYfM b] XYFYbXYfi b]	BUa Y	8Ua	8K : BC "	
 Valves & Regulators		çXl çH YdUf_ F Y [çb HfYf 9l fcdU5 XY%&) ((- ÖX Yb 8 Yl fH W Ubx Z (- fSt) S&- -) %& \$	8Ua . \$ " \$) & \$ %& BUa Y . A " çf [] ; YdF .	: &\$&\$\$\$\$ G7 5@9.%%	çXYI à
			5'	G-99H% C : %	