

: %&\$\$\$(\$

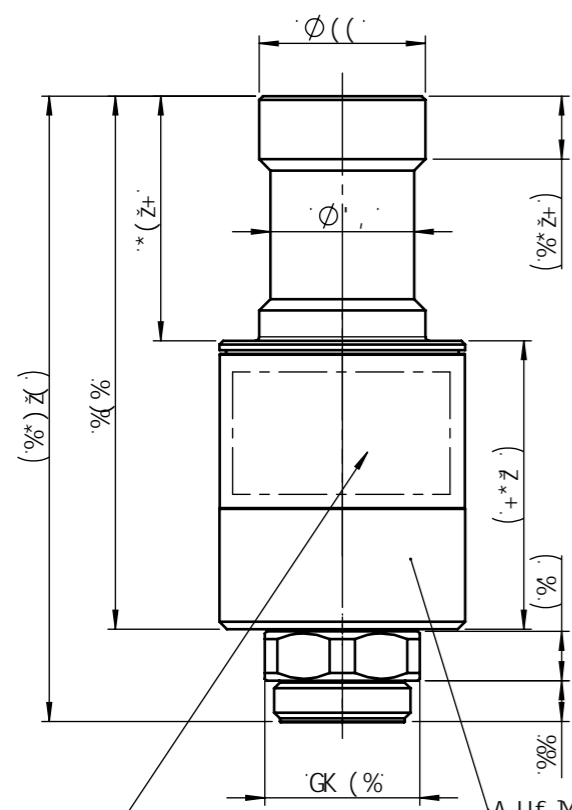

; Yfj hY ghY W\_Yf#WcbbY Wcfdi [.  
 8-B 9B %+) '\$%\$, '\$' :cfa '5  
 GhY W\_YfXcgY #gcW\_Yh  
 <fgW\ a Ubb; 8A '\$\$\$-

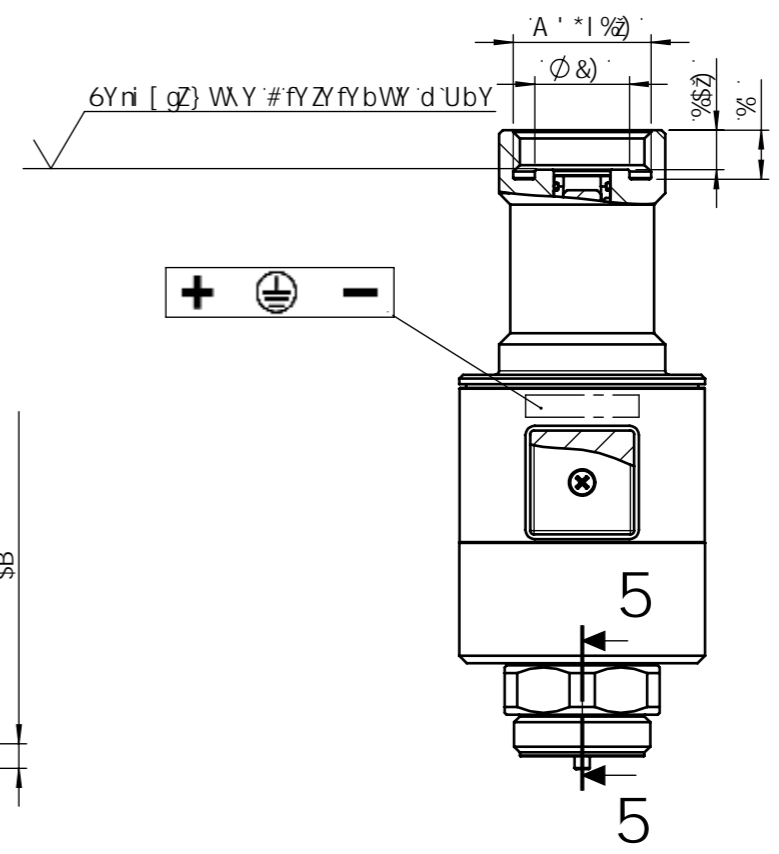
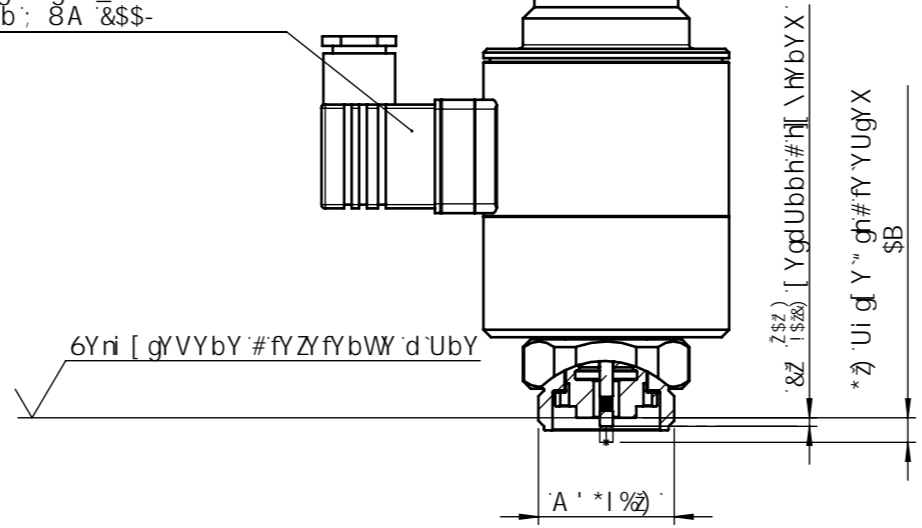

A Uf\_Yfi b[ #a Uf\_b[ .  
 !!!!!!!!!!!!!!!!!!!!!  
 5fh\_Y'bi a a Yf#WU'c[ 'bi a VYf..... : %&\$\$\$(\$  
 8Uhi a '#XUHY..... >>>>#K K  
 GdUbbi b[ /Gfca gh] f\_Y #] c'UJ [Y/W fYbhfUHY... &(J 87 #S\$) 5  
 N 'Uggj b[ gbi a a Yfb #Uddfcj U'bi a VYfg  
 8fy\ a ca Ybh#hcfei Y..... ) Ba

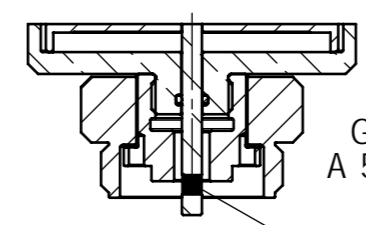
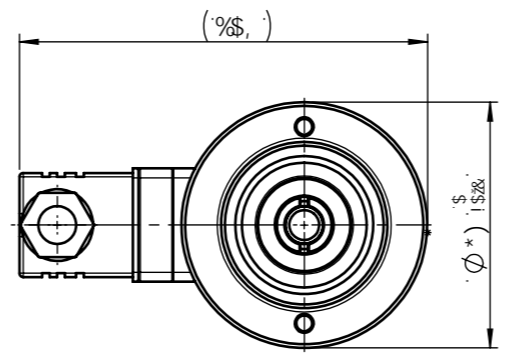

G7 < B #H5!5'  
 A 5 EG56' (%).

fc hY ?YbbnY M bi b[  
 gM hV Uf  
 fYX' a Uf\_b[ j jgV Y

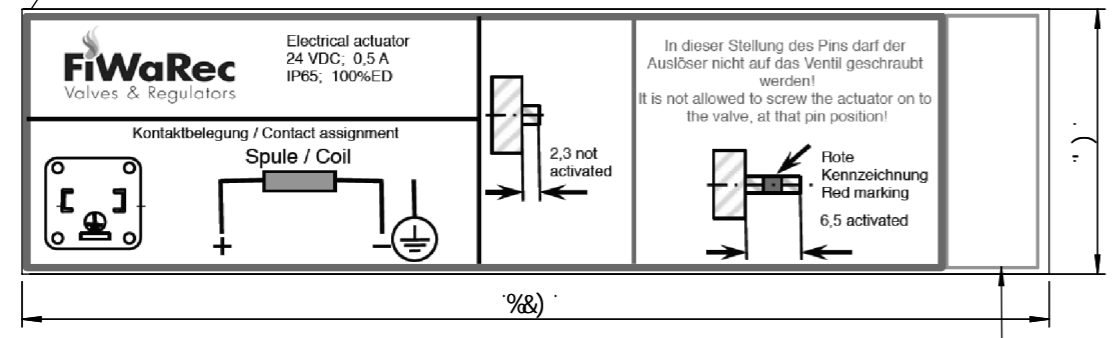
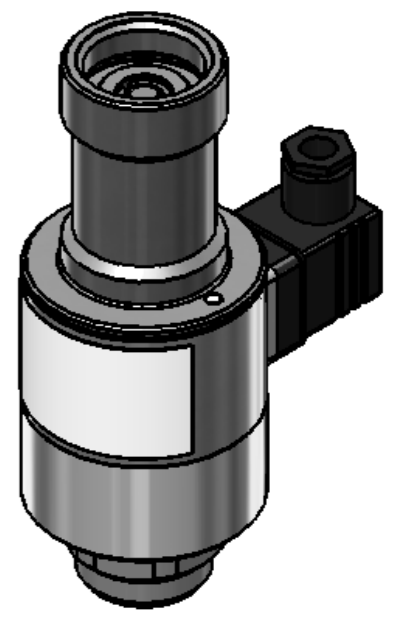

?YbbnY M bi b[ #a Uf\_b[ .  
 <YfgY' bi a a YfUi Z YXfi W\_hj jYfgY' [ 'Zc fhUi Zybx  
 a Ubi ZUWi fy' bi a VYfd f bhY XZci fX [ ] hVc bhbi ci g

**HYW b]gW Y'8 Uhb #HYW b]WU'8 UH**

0^•æ d æ•^A] cA ^ã @	G GE *
0f \{ æ•^A^•æ cA ^ã @A ] } *^!	FI G *
X^! [ ! * } *•• } } *^X [ cæ ^Aæ } ^	FI Aã A XOO
p^} , æ^! cæ a^A ^ã cæ OAD [ { a^A^! a^ã & Aæ GE O	I EA FEA U@
Ud { •cè \^A æ B^A^! V^! } A } a^UVAO' \!^! cæ GE O	EH CE
S^ac } *•æ } aq ^A æ KAUAU [ , ^! ] 'c	I E Y
Oã • & cæ æ ^! A O' c & & ^!	FEEA OO
W' *^à } *•c [ ^!æ   AOE aã } c^A [ ^!æ   ^	EEAã A I »O
Q [   a'•d -   æ•^A æ KOOA   EAO'   æ } Aæ•	Ø
U&@ c æ d æ QOA E   EAU [ c & a } Aæ • AOA OOA   E	QAI
S^a^} •æ æ ^! Q&cæ ^! ^! DSA cã ^! & ^!	I EE

**GMXU'h b[ 'A U[ bYh\_f]gUi Z#7 c] 7 jW jh**

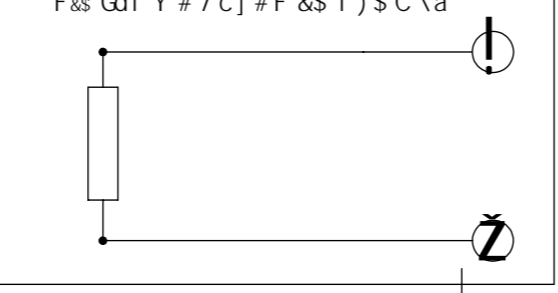

5' [ Ya Y]bte YfUbnYb bUW 8-B -GC &+ , 1%a	Hc YfUbnYb ZOf: cfa 'i bX @U [Y bUW 8-B -GC &+ , 1&<	5' Yi bVYa U_bYb ? UbYb i bX FUXYb. F S\$&	: Yk Mh	I B@9GG CH<9F K -G9 GD97 = 9B. 8-A 9BG-CBG 5F 9-B -A @A 9H9F G
			A UH fU:	
			HY:	9'Y_f]gWYF'5i g'QgYf ZOf: &\$& Y'YVW'W' fY'YUgY XYj M' Zc f: &\$&
			8K: BC'	: %&\$\$\$(\$ A %%
			5'	G7 5@9.%& G<99H% C: %
			8Uhi a . & '\$' '\$&\$% BUa Y. : Y'Yb ; YdF.	ØXYI
			à	