

: %&\$\$\$\$&

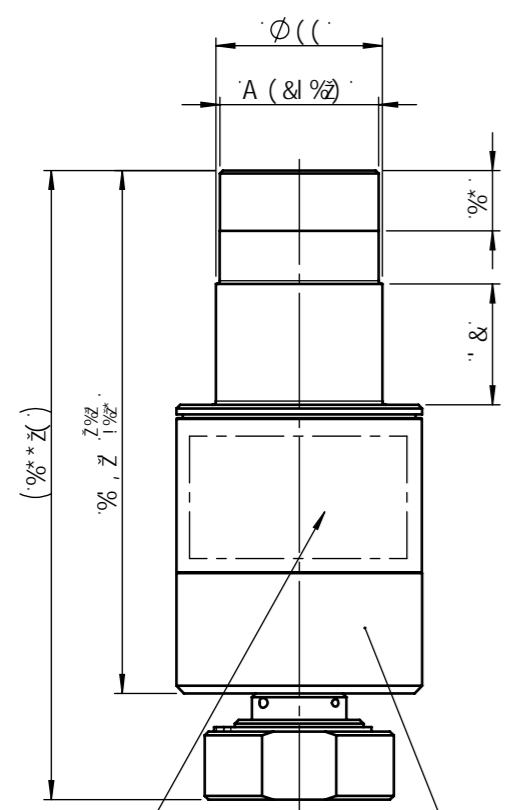

: Yf} hY gY WYf # WcbbY Wcfdi [.
 8-B '9B %+) '\$% , '\$' : cfa '5
 GY WY fX cgy # gcWYh
 < fgm a Ubb ; 8A &\$\$-

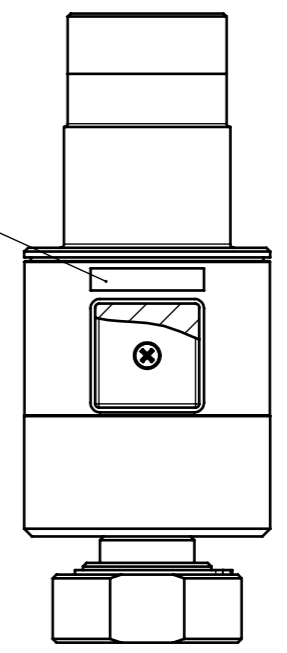
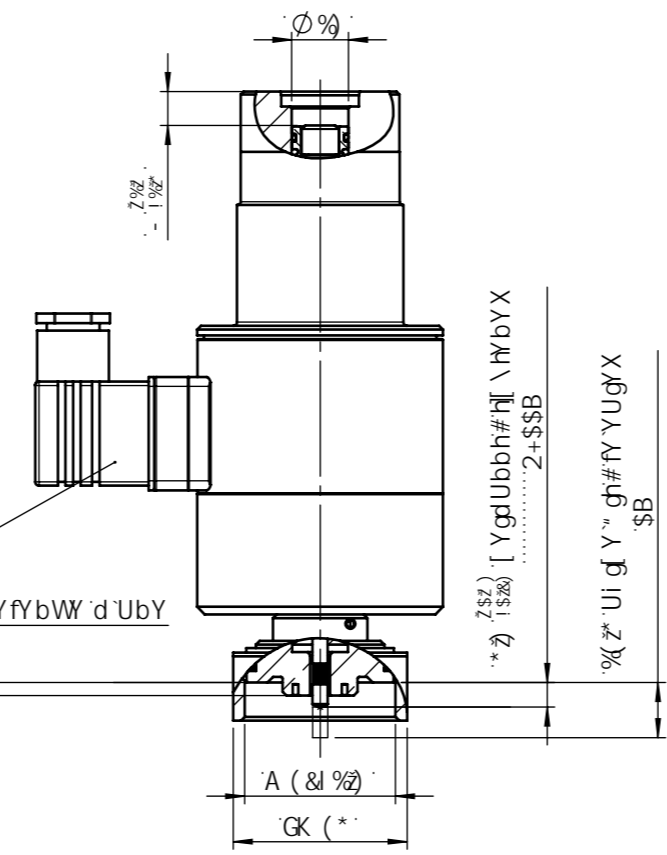

A Uf_Yfi b[#a Uf_b[.
 !!!!!!!!!!!!!!!!!!!!!
 5fh_Y'bi a a Yf#WUH'c['bi a VYf..... : %&\$\$\$\$&
 8U'h a #XUHY..... >>>>#K K
 GdUbbi b[/Grca gh_f_Y #j c tU[Y/W fYbhfUHY. &(J 87 # \$Z) 5
 N 'Ugg b[phi a a Yfb #Uddfj U'bi a VYfg
 8fy \a ca Ybh#rcfei Y.....) Ba

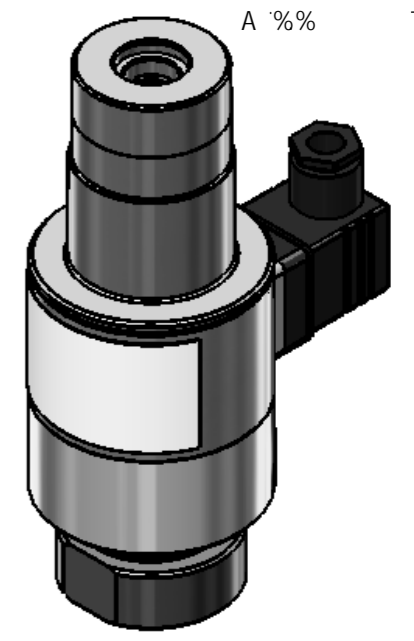
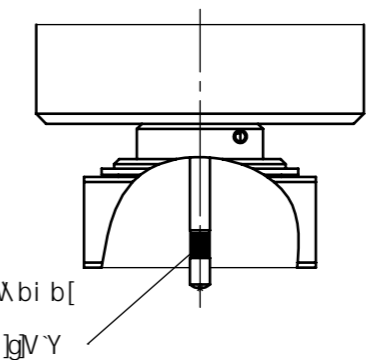
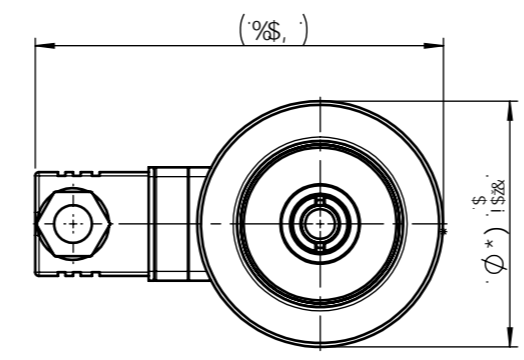
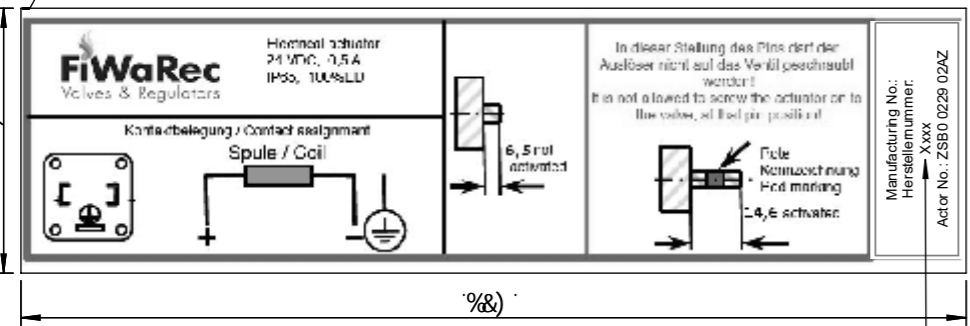

?YbbnY jW bi b[#a Uf_b[.
 < YfgY 'bi a a YfUi Z YXfi W'hj YfgY 'j' ZcfhUi Zybx
 a Ubi ZUWh fy 'bi a VYfd fphY XZci f iX[] hWc bh bi ci g

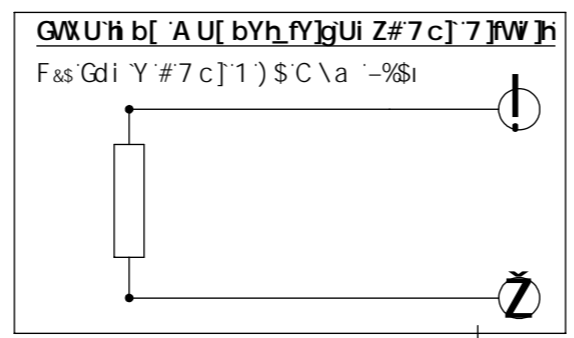

5' [Ya Y] bte YfUbnYb BUW 8-B -GC &+, 1%a	Hc YfUbnYb ZDF: cfa 'i bX @U[Y bUW 8-B -GC &+, 1& <	5' Y'i bVYa U'Yb ? UbYb i bX FUXjyb. F \$Z&	: Yk jW h	I B@9GG CH<9F K -G9 GD97 = 9B. 8-A 9BG<CBG 5F 9-B A @A 9H9F G
			A UH'UJ:	
			9 Y_fjgWYf 5i g'GgYf ZDF: &\$% Y'YW jW fY YUgY XYj jW Zcf: &\$%	
			8K : BC*	⊖XYI
			: %&\$\$\$\$&	&
FiWaRec Valves & Regulators			5'	G7 5@9.%& G<99H% C : %

HYW b]gW Y'8 UhYb #HYW b]WU'8 UH	
O^•a d a•^A V[ca A^a @	G GE *
Q\^ { a•^A^•a d A^a @ A^a } *^!	FI G *
X^ { } *^•• a j } *^ AX[ca^A a j } *^	FI A a G XOO
P^ } a^ •ca a^A a^G OAP[a a^ a^a a^ca & A^G O	I CA FEA U @
Ud { •c i^A a^A a^A V^ } A } a^U V^O ^ } a^G O	EF CE
S^a c } *^ a j } a g ^A a^G a^U A U[, ^ a j } c	I E Y
O a •& ca a^A^O c^& g^	FEE A^OO
W *^a^ } •c^ ^ a^e^ A^O a^A^ ^ a^e^ ^	EE A a A I »O
Q a^•d - a^•^A a^G OAP[€ A^O a^ } A^a •	Q A O
U @ c a^a a^G O A € € A^U c^& a } A^a •O O A^O A €	Q A
S^a^ } a^e^ A^U & c^ ^ } D^a e^ { & g^	I €€