

: \$% \$\$\$&

5

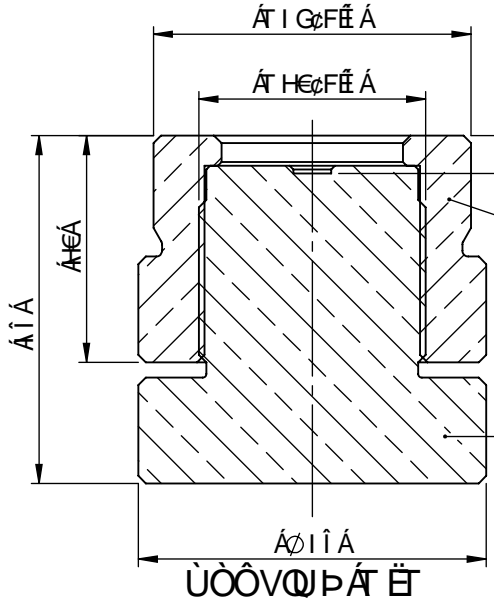

%  
 @ä å^• öã ä { ÅË • &Qæ  
 ä ÅÖFGEÉEGÅ &@æ à^} Æ  
 •&^ ^ãÉ Åöä äÉä @Å d  
 ÖFFGÉEGÅ } äÅ^ã \* Å|| & ^ã

&"  
 @ä å^• öã ä { ÅË • &Qæ  
 ^ã • &@æ à^} Æ  
 •&^ ^ãÉ Åöä äÉä @Å } äÅ  
 à^ã \* Å|| & ^ã

6

7

T æ\ ä: } \* ÅÄ æ\ ä \* K  
 æ\ ä\ Å { à\ i\ ÅÖFÉ ÉEG  
 äæ^ Å - Å æ ~ æ&C |^Å { Æ  
 @^ æ\ i\ ÅÖFÉ I GcFÉ  
 { æ ~ æ&C |^i\ Å [ Åæ ^

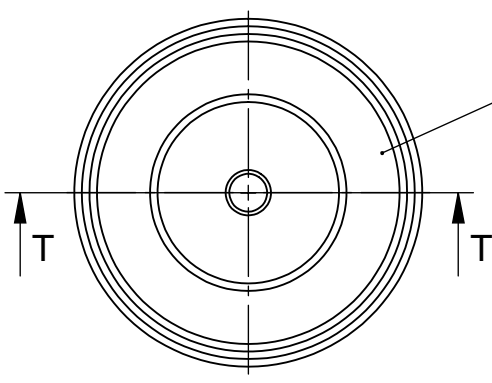

8



\*^!ê} å^|Ð  
 \} ~ |^å

\*^!ê} å^|Ð  
 \} ~ |^å

9

5" [Ya Y]hc YrUbnYb bUW 8-B -GC &+*, !%a		Hc YrUbnYb ZÖF: cfa i bX @U[ Y bUW 8-B -GC &+*, !& <		5" Y i bVYa U» Hb? UbHb i bX F UX]yb. F \$Z&		; Yk ]Mh		I B @9GG CH-9FK -G9 GD97 ÷ -98. 8-A 9BG-CBG 5F 9 -B A -æA 9H9F G		
						A UYf]J.				
V %&\$) & rk Y ]H Y] [ Y J Y fg]c b				?G &(" \$- "%&		Hf]Y.		F ØWgHY`k Yf_nYi [ `ZÖF: %&\$\$\$\$&		
U %&\$' "				A @ &%\$* "%&				fYgYhlc` Zf: %&\$\$\$\$&		
: ÆXYI YbXYfi b[		öYgWf]M b[ XYFYbXYfi b[		BUa Y BUa						
 Valves & Regulators		ÆXi gff]YdUF_ F Y] ]cb Hf]Yf 9i fcdUf5`YY %& )(' (: ÖUfYb 8Yi HgW.UbX Z(- fSE*) \$&- ' -) %&\$		8Uhi a . \$, "\$) "%& BUa Y. GcbbY ; Ydf".		5(		NY]Mbi b[ gbi a a Yf.  : \$% \$\$\$&		ÆXYI  à
						A U» gHUV.%%		G< 99H% C: %		