

# Flowmeter

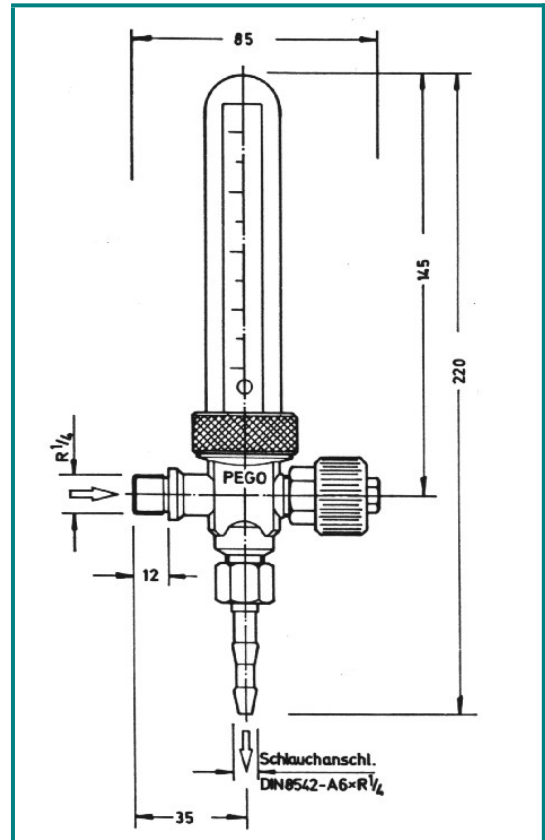

Model	Gas	Operating pressure	Inlet connection	Outlet connection
Flowmeter	F, NF, NC	max. 2,5 bar	G <sup>1</sup> / <sub>4</sub>	G <sup>1</sup> / <sub>4</sub> DIN EN 560 G <sup>3</sup> / <sub>8</sub> LH DIN EN 560

N <sub>2</sub>	CO <sub>2</sub> Ar	Formiergas	H <sub>2</sub>
1-16 l/min 4-32 l/min	1-16 l/min 3-30 l/min	1-16 l/min 2-30 l/min	1-16 l/min 3-30 l/min

The Flowmeter can be used for inert gas welding and by laboratory normalising ovens to control the gas flow.