

Precision pressure regulator FHR 125



Description:

The precision pressure regulator FHR 125 serves the pressure reduction of air and neutral gases down to pressures within the mbar range. This is reached by a very thin diaphragm from strengthened synthetic rubber, as well as a cantilever transmission for the actuation of the valve piston.

The diaphragm housing can be rotated steplessly against the tubing ports. Thus a horizontal adjustment of the diaphragm is possible in all installation positions.

An optionally installed blow-off valve is in the position to regulate excessive pressure on the outlet pressure side.

Application area:

The particular area of application of these pressure control valves are where high requirements are required in accuracy, stable regulation, as well as durable building quality. Through different valve seat diameters, as well as various adjusting springs, these pressure control valves can be individually adjusted to the requirements needed e.g. as tank ventilation regulators and burning and heating gas regulation.

Technical details:

Casing:	aluminium
Valve seat:	aluminium Ø3,5 to Ø10
Seat gasket:	NBR
Diaphragm:	NBR
max. inlet pressure:	1,7 / 2,5 / 5 / 10 bar
Regulating area:	5 mbar to 300 mbar
Operating temp.:	-20°C to +80°C
Size:	233 x 161 x 156
Weight:	1800g
Connections:	in / outlet G 1"

Hornung Quality standard

The company Hornung is certified to

DIN EN ISO 9001 and ISO 14001:2009.

All single parts are manufactured, assembled and tested in house.

The finished parts are therefore under the criteria of our exact quality control with 100% final control.

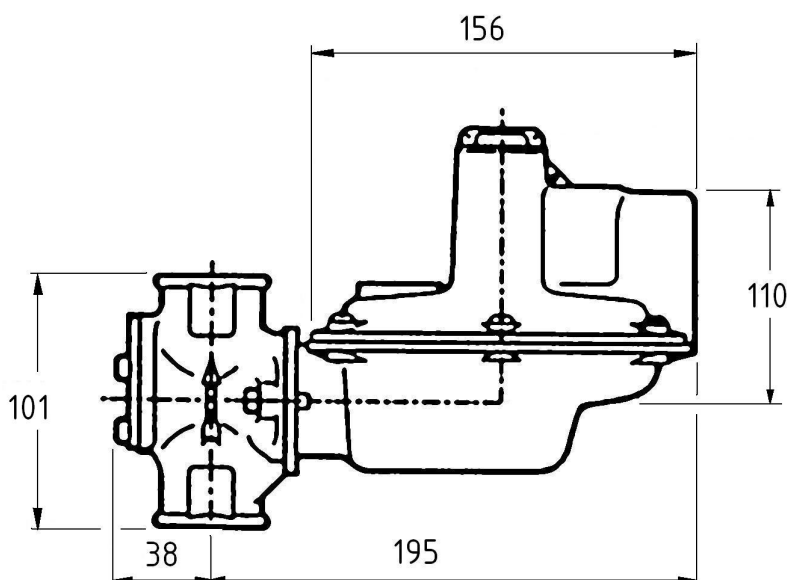

Performance diagram:

FHR 125

See data sheet / sides 3 and 4

The following performance diagrams are the maximum throughput with completely opened valve depending on seat size with given in and outlet pressures.

To achieve a good controlling action of the pressure regulator, no more than 90% of the indicated flow rate should be used.

Order details:

Seat size:

- 1 = 3,5 mm
- 2 = 5,0 mm
- 3 = 8,0 mm
- 4 = 10,0 mm

Pressure area:

- 1 = 5 - 15 mbar
- 2 = 12 - 25 mbar
- 3 = 22 - 35 mbar
- 4 = 32 - 50 mbar
- 5 = 45 - 75 mbar
- 6 = 70 - 140 mbar
- 7 = 100 - 300 mbar

Blow-off valve:

- S1 = without blow-off valve
- S2 = with blow-off valve

Order example:

Regulator type	
18	FHR 125

18	- 1	2	S2	Gas
typ	Seat	Pressure	Valve	Gas

Accessories:

- Flanges DN 25 / PN 10 / Form C

The following performance diagrams are the maximum throughput with completely opened valve depending on seat size with given in and outlet pressures.

To achieve a good controlling action of the pressure regulator, no more than 90% of the indicated flow rate should be used.

Flow rate in Nm³/h (Air) for FHR 125

Seat / Nozzle 3,5 mm; Inlet pressure max. 10bar

Spring range (mbar)	5 - 15	12 - 25	22 - 35	32 - 50	45 - 75	70 - 140	100 - 300
Setting pressure (mbar)	10	20	30	40	60	100	200
Inlet pressure (bar)	Nm ³ /h	Nm ³ /h	Nm ³ /h	Nm ³ /h	Nm ³ /h	Nm ³ /h	Nm ³ /h
0,25	5	4	5	5	5	5	5
0,50	7	6	7	8	8	7	6
0,75	9	9	10	10	10	10	9
1,00	12	11	11	11	11	12	12
1,25	13	13	13	13	14	13	13
1,50	15	15	14	14	14	14	14
2,00	18	17	16	16	16	18	17
2,50	21	20	20	19	19	20	20
3,00	23	23	22	22	22	23	22
3,50	27	26	25	25	25	26	25
4,00	29	29	28	28	28	28	29
5,00	35	35	35	35	35	34	34
6,00	41	41	41	41	41	41	41
7,00	47	47	47	47	47	47	41
8,00	53	53	53	53	53	53	53
10,00	54	54	54	54	54	54	54

Seat / Nozzle 5,0 mm; Inlet pressure max. 5bar

Spring range (mbar)	5 - 15	12 - 25	22 - 35	32 - 50	45 - 75	70 - 140	100 - 300
Setting pressure (mbar)	10	20	30	40	60	100	200
Inlet pressure (bar)	Nm ³ /h	Nm ³ /h	Nm ³ /h	Nm ³ /h	Nm ³ /h	Nm ³ /h	Nm ³ /h
0,25	67	8	8	8	8	7	8
0,50	15	13	14	13	13	12	12
0,75	20	18	19	17	18	15	16
1,00	23	23	23	23	22	21	22
1,25	26	26	26	26	26	25	25
1,50	29	29	28	29	29	28	28
2,00	35	35	34	34	34	33	34
2,50	41	40	40	40	41	40	40
3,00	47	46	46	46	47	46	46
3,50	53	52	51	52	52	51	53
4,00	58	58	57	58	58	58	58
5,00	67	69	69	69	69	69	68

Seat / Nozzle 8,0 mm; Inlet pressure max. 2,5bar

Spring range (mbar)	5 - 15	12 - 25	22 - 35	32 - 50	45 - 75	70 - 140	100 - 300
Setting pressure (mbar)	10	20	30	40	60	100	200
Inlet pressure (bar)	Nm ³ /h	Nm ³ /h	Nm ³ /h	Nm ³ /h	Nm ³ /h	Nm ³ /h	Nm ³ /h
0,10	11	10	10	9	8	--	--
0,25	12	17	17	17	17	12	--
0,50	29	31	31	29	28	23	23
0,75	42	43	42	40	40	33	30
1,00	51	50	50	50	51	38	39
1,25	60	58	62	59	61	45	44
1,50	65	63	70	67	67	53	51
2,00	84	74	83	83	80	68	64
2,50	95	90	97	97	93	87	87

Seat / Nozzle 10,0 mm; Inlet pressure max. 1,7bar

Spring range (mbar)	5 - 15	12 - 25	22 - 35	32 - 50	45 - 75	70 - 140	100 - 300
Setting pressure (mbar)	10	20	30	40	60	100	200
Inlet pressure (bar)	Nm ³ /h	Nm ³ /h	Nm ³ /h	Nm ³ /h	Nm ³ /h	Nm ³ /h	Nm ³ /h
0,05	11	7	6	--	--	--	--
0,10	12	11	10	10	8	--	--
0,25	21	21	22	21	21	18	--
0,50	35	35	36	35	34	28	21
0,75	50	50	53	50	50	42	31
1,00	61	66	65	61	59	58	50
1,25	73	76	75	73	70	72	65
1,50	82	91	85	86	83	76	74
1,70	91	91	94	92	92	83	76