

# Central pressure regulator ZD 400

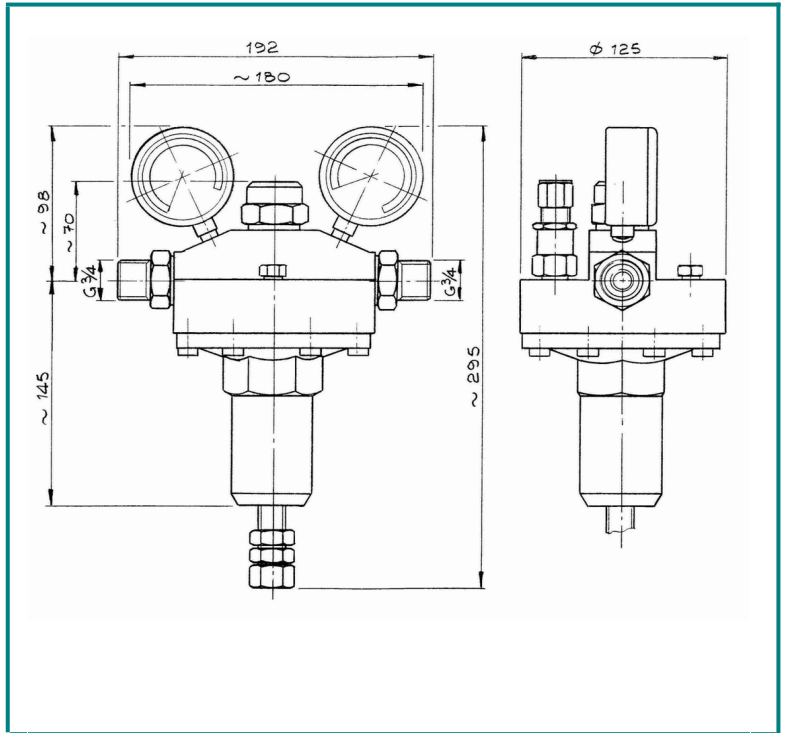

Model	Gas	Inlet pressure P1	Outlet pressure P2	Flow Q1	Inlet connection	Outlet connection
ZD 400	NF, F, NC	max. 300 bar	max. 0-20 bar	340 m <sup>3</sup> /h	G <sup>3</sup> / <sub>4</sub>	G1

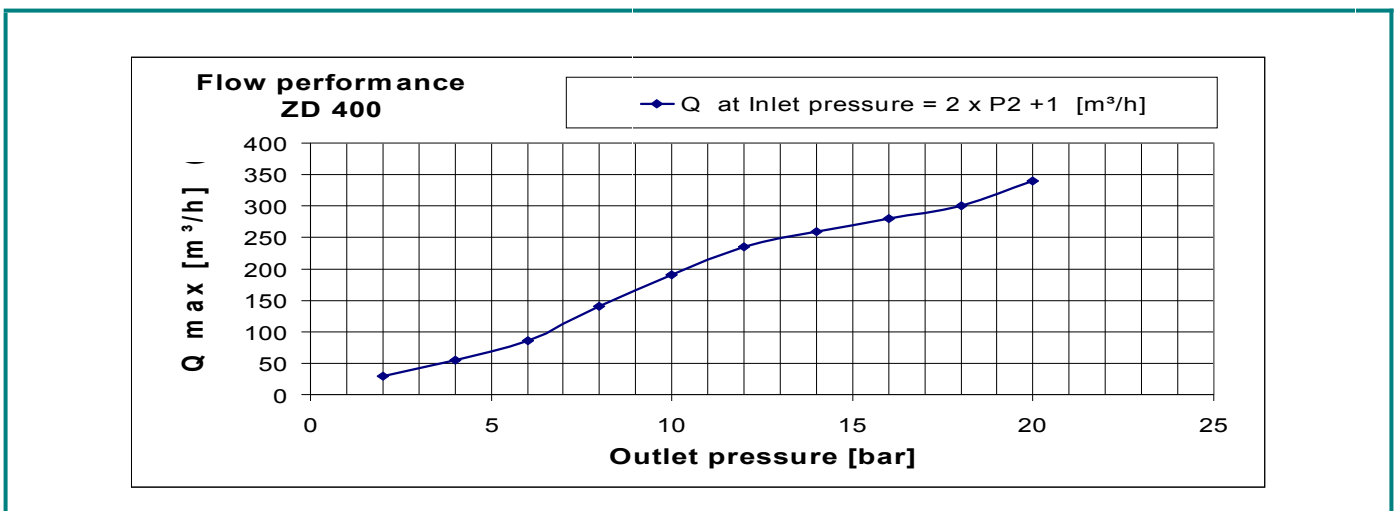

The pressure regulator ZD 400 reduces the max. inlet pressure of 300 bar down to a max. outlet pressure of 20 bar.

The ZD400 is a single stage diaphragm controlled regulator with an inlet pressure compensator. A specifically constructed piston version assures constancy in pressure. BAM certified for Oxygen.