

Gas supply station ZD 150 portable

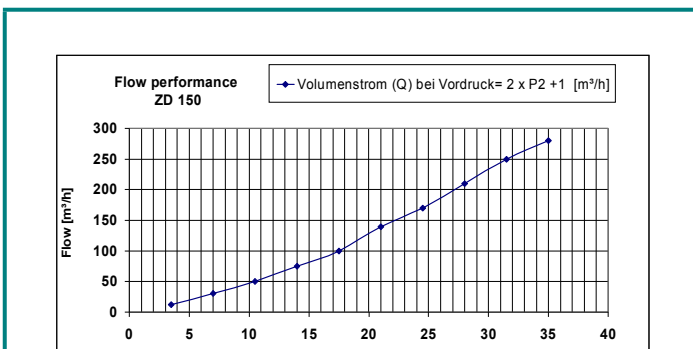
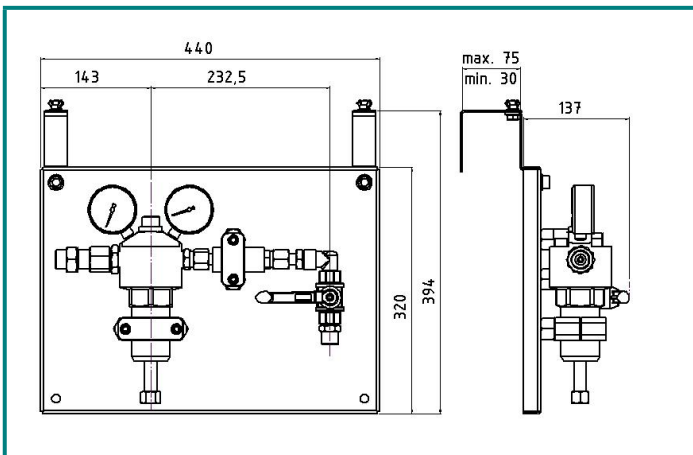
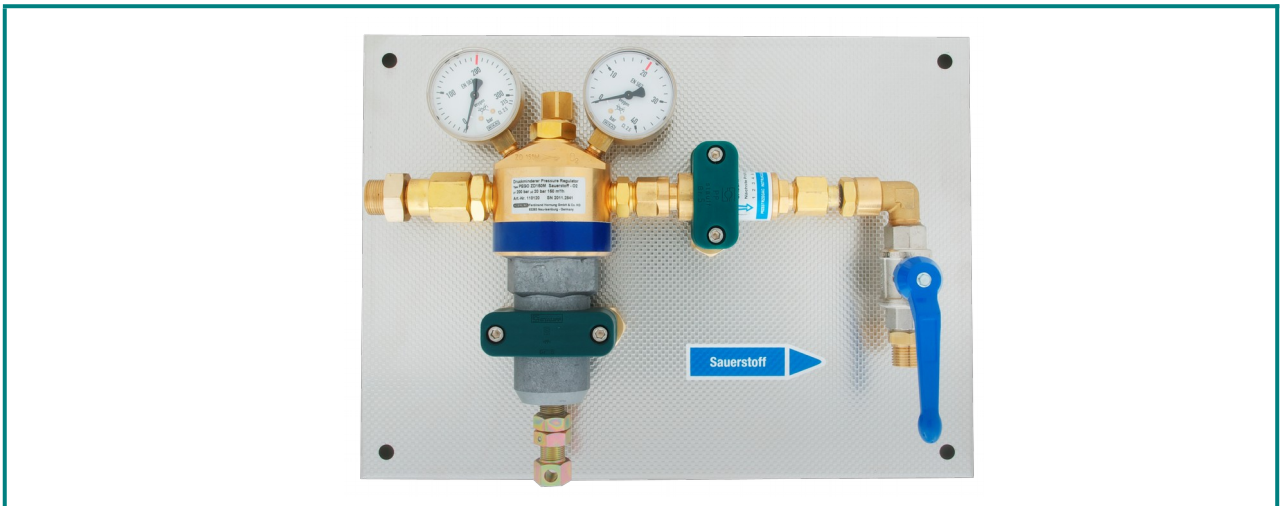

Hornung Quality standard

The company Hornung is certified to **DIN EN ISO 9001 and ISO 14001:2009**. All single parts are manufactured, assembled and tested in house. The finished parts are therefore under the criteria of our exact quality control with 100% final control.

Description

The gas supply station ZD 150 is a single sided Oxygen supply unit.

The construction of the basic console with brackets enables the use on different locations e.g. cylinder bundles. A permanent installation is also possible.

With the supply station ZD 150 a maximum pressure of 300 bar can be reduced to a maximum pressure of 10, 16, 20 or 35 bar and held constant.

The supply station consists of a single stage central pressure regulator to DIN EN 961 (ISO 7291) with BAM Oxygen certification. The integrated relief valve protects the valve from excessive outlet pressure.

The installed safety equipment guarantees safe gas supply according to EN 730-1.

A shut-off valve installed at the outlet ensures a complete gas flow stop.

Hornung GmbH
Rathenaustraße 55, 63263 Neu-Isenburg

Phone: +49 6102 7883-70
Fax: +49 6102 7883-40

www.hornung.org
info@hornung.org

INFO:
Safety equipment

Always in use where high gas flows are needed by minimum pressure loss. The high gas flow is a guarantee for longer life, higher safety and functionality.

Safety elements:

- Non-return valve
- Flame arrestor
- Thermal cut-off valve

Long life through installed dust filter

Test specification Safety arrangement:

Equipment should be tested at least bi-annually.

Test equipment can be supplied on request.

Safety equipment can be repaired and serviced by the manufacturer.

Technical details:

Material: brass
Seat: EPDM
Filter: metal, Pore size 40µm
Diaphragm: stainless steel
Max. Inlet pressure: 300 bar
Max. Output: 280 m³/h
Regulating area: 1,0 – 35 bar
Operating temp.: -20°C to +60°C
Size: 440 x 320 x 137 mm
Weight: 8000g

Order details:

Inlet pressure (p1):

1 = 200 bar
2 = 300 bar

Outlet pressure (p2):

1 = 1-10 bar
2 = 1-16 bar
3 = 1-20 bar
4 = 1-35 bar

Order example:

Station-Type	
47	Station ZD 150 portable

47-	1	2	Gasart
Typ	p1	p2	Gasart

Accessories:

- ZDA 25 Station, portable
- Gas manifold, portable
- Low pressure hose to station
- High pressure hose to cylinder bundle

